

Modular processing unit range for stationary CNC production

The right unit for
every aspect
of complete
processing

Sophisticated technology for demanding applications

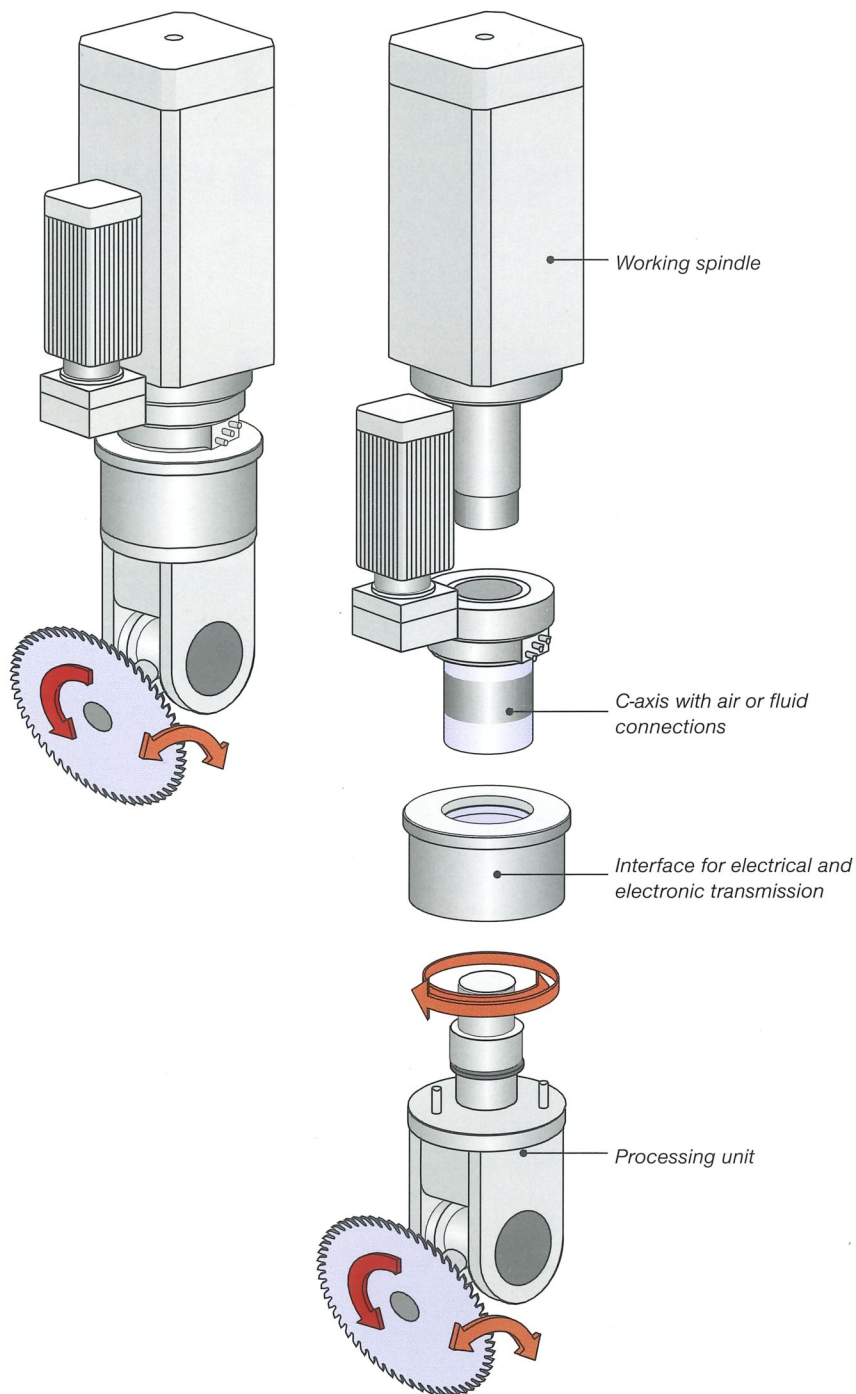

Windows today, doors tomorrow, furniture elements the day after... The extreme flexibility of Homag processing centres and routers with their versatile units opens up scope for practically unlimited production possibilities.

The modular processing units

The units required for each individual processing stage are fully automatically exchange mounted by a tool change system into the machine's working spindle, with 0 - 360° swivel facility via the C axis. Depending on the application, they can also be fitted with pneumatic connections. A selection of the most important units is described in the following. If the most suitable solution for your specific processing requirement is not represented here, simply ask us. There are a range of additional units available in the range, which is being continuously updated and extended.

Main spindle

External drive via main spindle with 14,5 or 21 kW

C axis:

C axis for rotation

Pneumatic

and pneumatic supply

Trimming tool uses drive system



Open-ended interface



Horizontal 4-spindle drilling head uses drive system and C axis



Flush trimming unit with tracing uses drive system, C-axis and pneumatic system

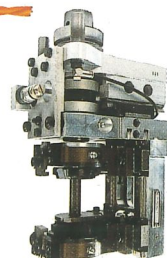

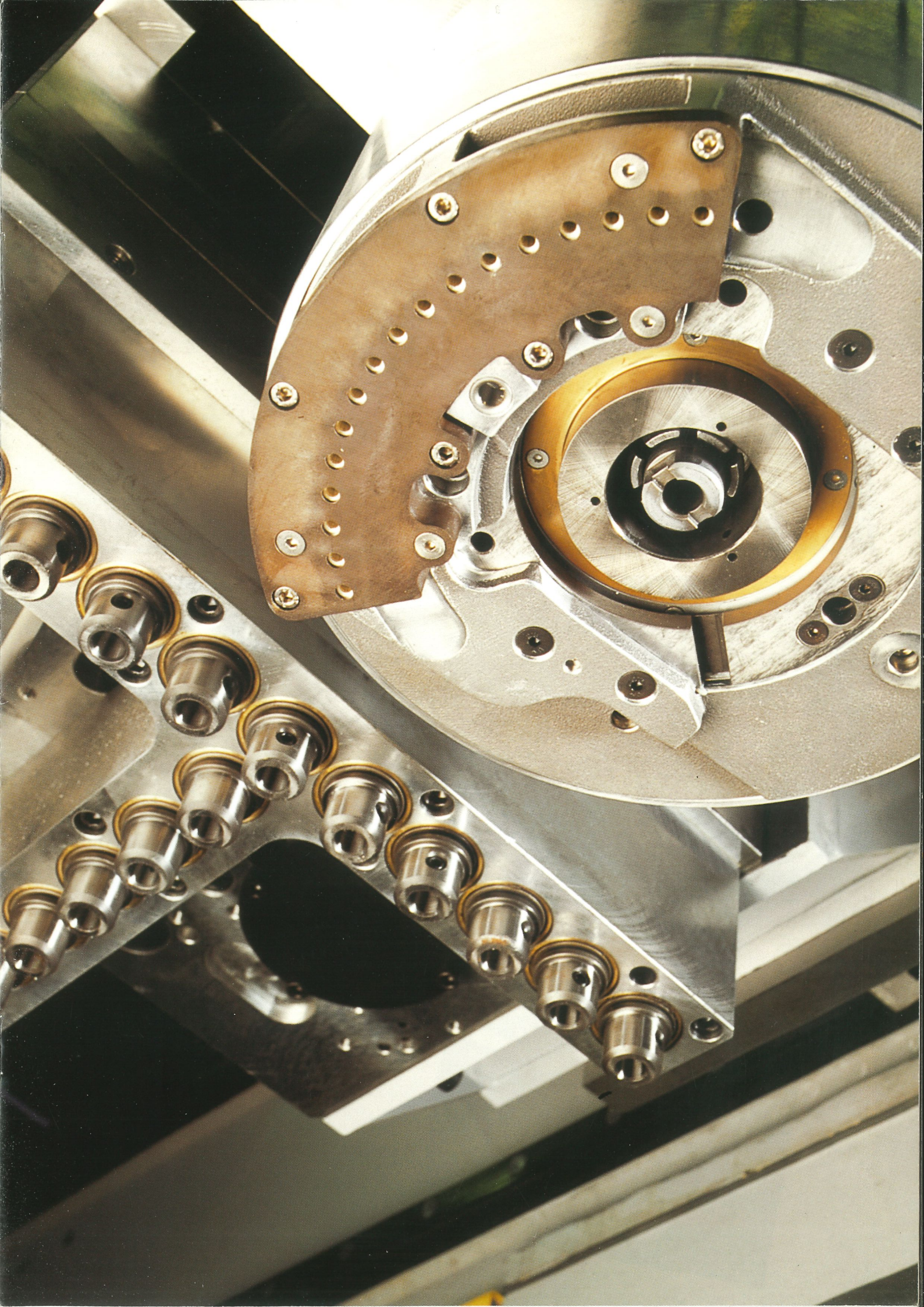

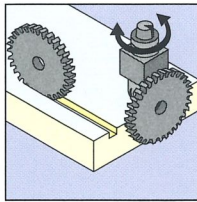
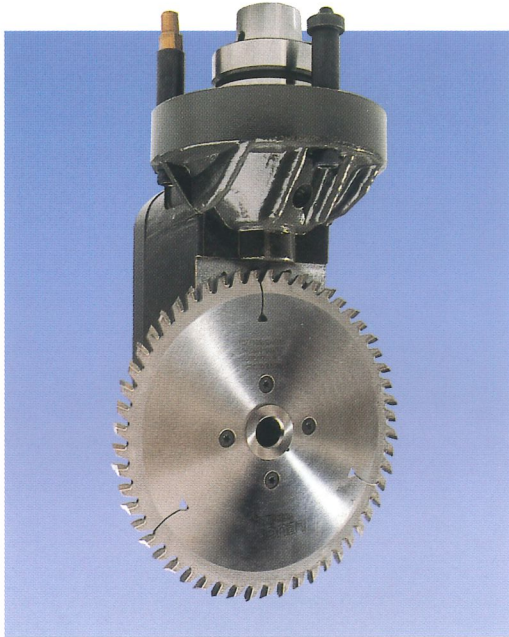

Sawing and snipping unit

Due to use of the C axis, sizing, grooving, snipping and dividing cuts can be performed, and recesses or notches sawn.

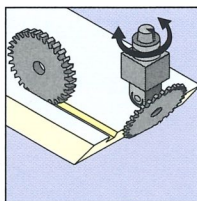

Swivel-mounted sawing / drilling unit

For sawing cuts and boreholes at any angle from 0 (vertical) to 90 (horizontal) degrees. The angle (B axis) can be manually adjusted. Applications: Mitre cuts, hinge holes on doors etc.

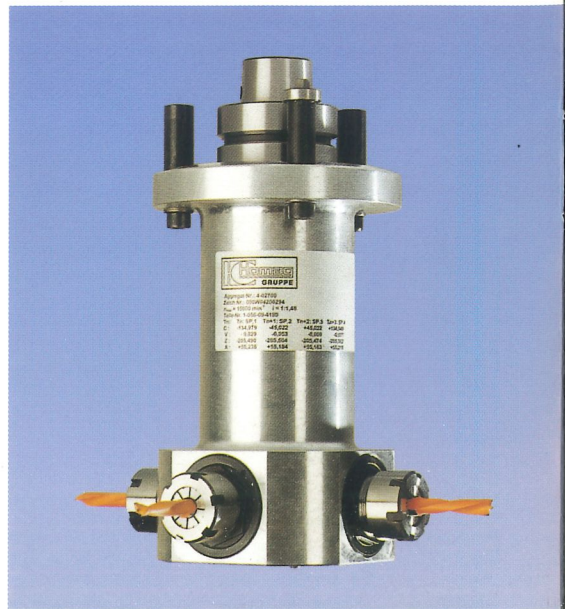
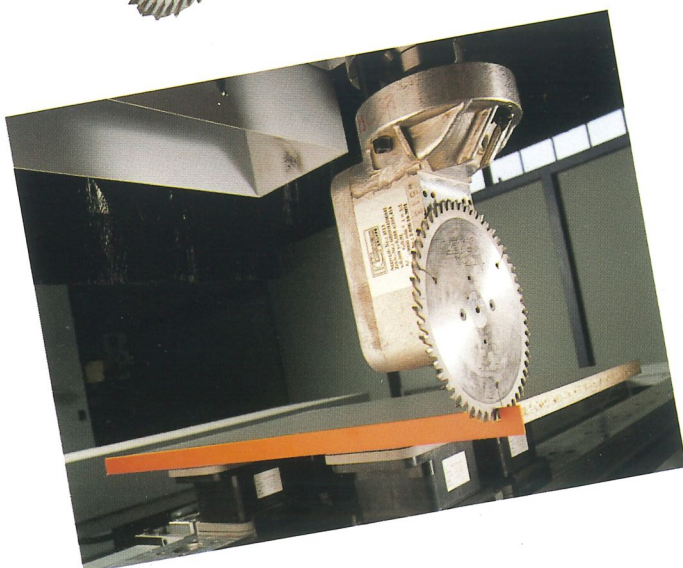
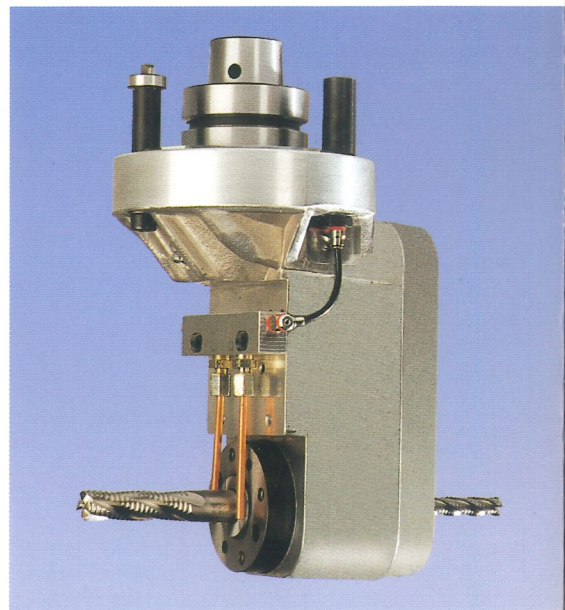

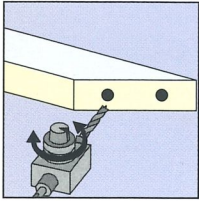

Two-spindle sawing and drilling unit

For horizontal drilling and light trimming work, for example grooves or oblong holes. Can be equipped as a sawing unit on one side. Max. saw blade diameter 240 mm.

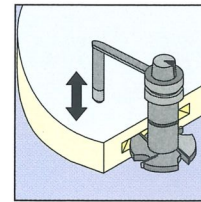
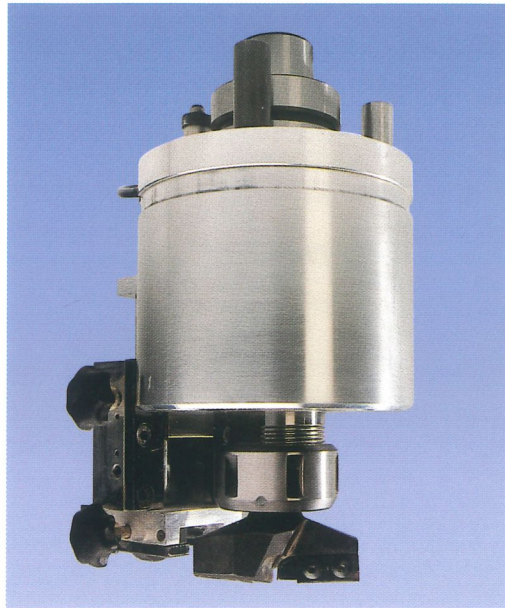

Vertical trimming unit, with tracing pad

For trimming work on the panel surface or on profiles. Processing of workpieces with overhanging edges is also possible.

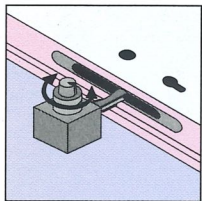

Two-spindle sawing and trimming unit

For trimming jobs, for example lock cases and rebates in doors, for drilling work etc. with integrated cleaning air jet, spindle extension on two sides turning in counter-rotation.

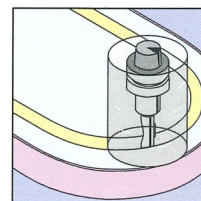

Vertical trimming unit with bell-shaped tracing device

For grooving and engraving work in the panel surface with tracing on the surface. Bell-shaped tracing device with integrated air jet.

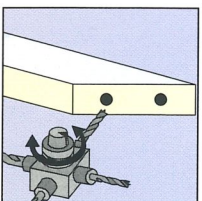

Trimming unit, 4 horizontal spindles

For drilling and trimming work such as grooves, oblong holes, notches and trimming of edges at any optional angle.

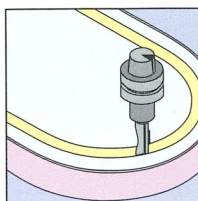
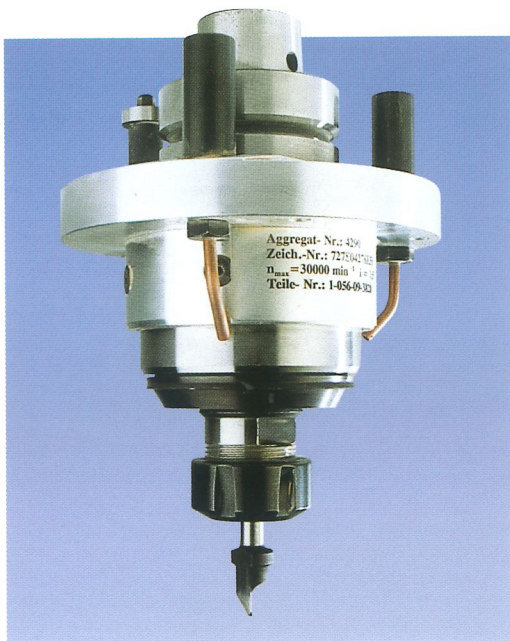

Trimming unit with reduction gear

To trim grooves or engravings with small tool diameters. An integrated speed transforming gear permits a maximum speed of 30.000 rpm to be achieved. This permits a higher cutting speed for small tools and so higher feed rates coupled with improved trimming quality.

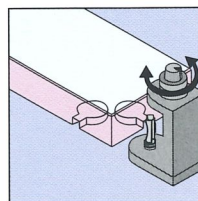
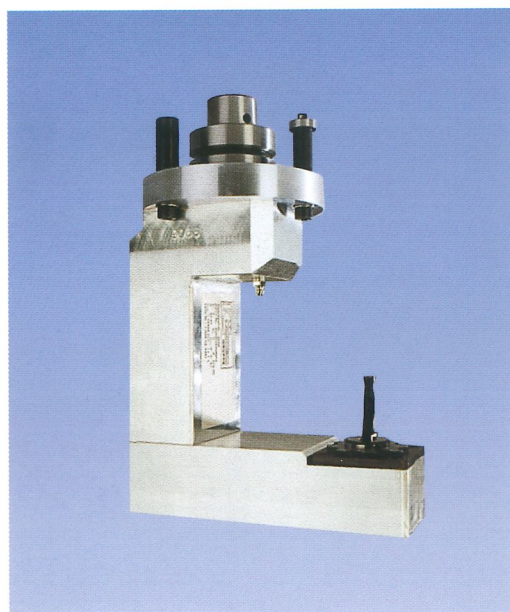
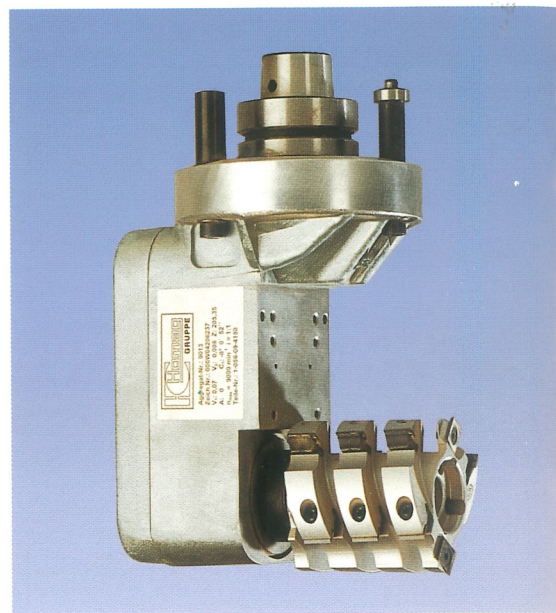

Underfloor trimming unit

For drilling and light trimming work underneath the panel, e.g. joining of worktops, spindle pointing vertically upwards. Max. overhang to the outside edge of the workpiece: 100 mm.

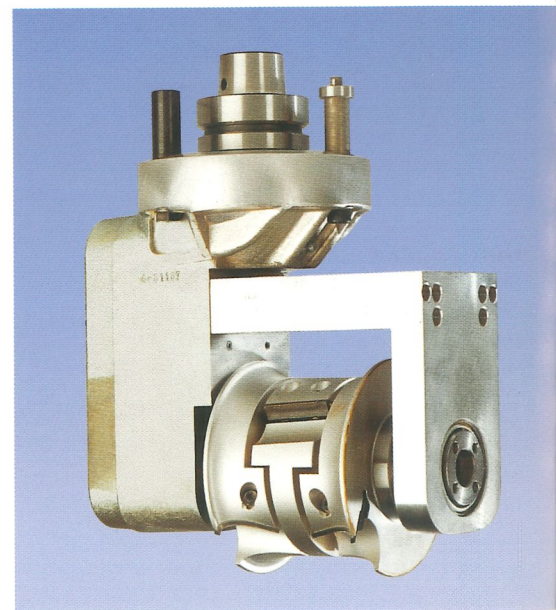

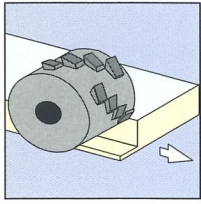

Horizontal trimming unit
Bevel gear with horizontal shaft for mounting sawing or trimming tools, swivel facility via the C axis.

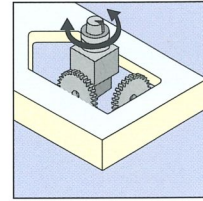
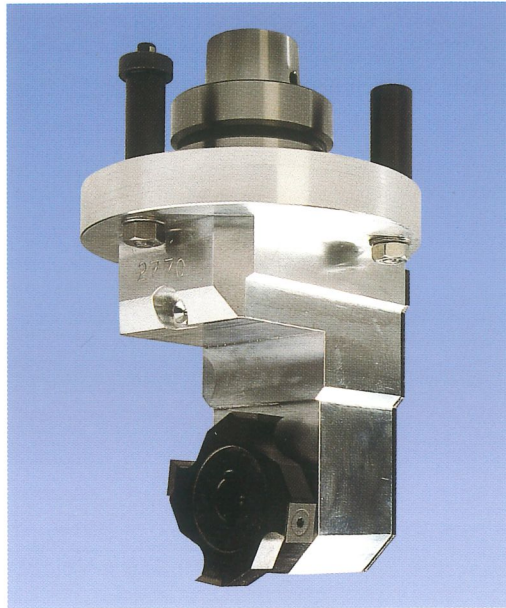

Corner notching unit
For the manufacture of right-angled, tear-free, sharp-edged internal recesses as required, for example, for ventilation slits or in the production of work-tops.

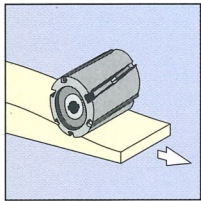

Unit for planing cutter head
For horizontal trimming and planing work on or in the work-piece surface, for example solid wood processing or trimming curved components such as table legs.

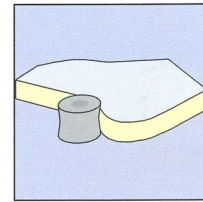
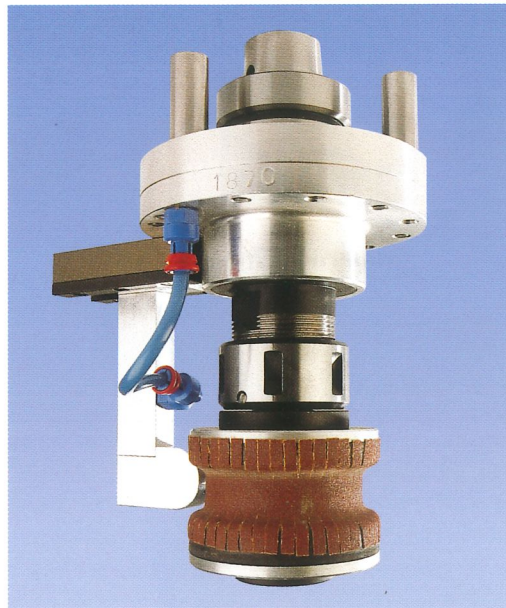

Retainers for sanding disks
For sanding work primarily on solid wood edges or MDF panels. The sanding disk is clamped in a standard DIN collet chuck and continuously cleaned with compressed air using an air jet.

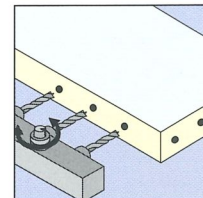
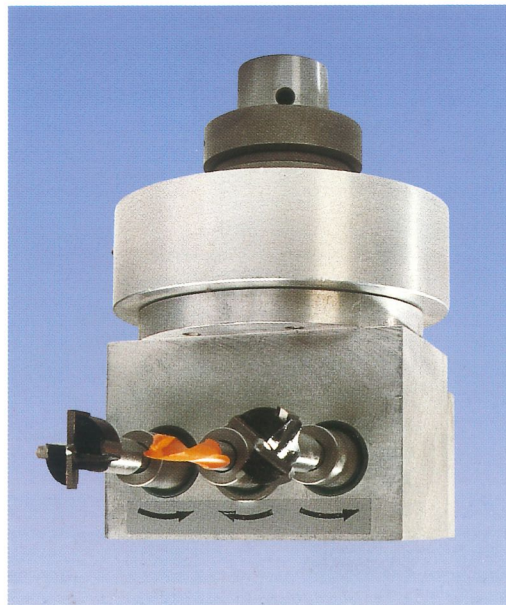

3-spindle horizontal drilling head
Swivel mounting by means of C axis by 360 degrees. Drill spacing 32 mm.

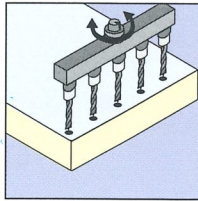
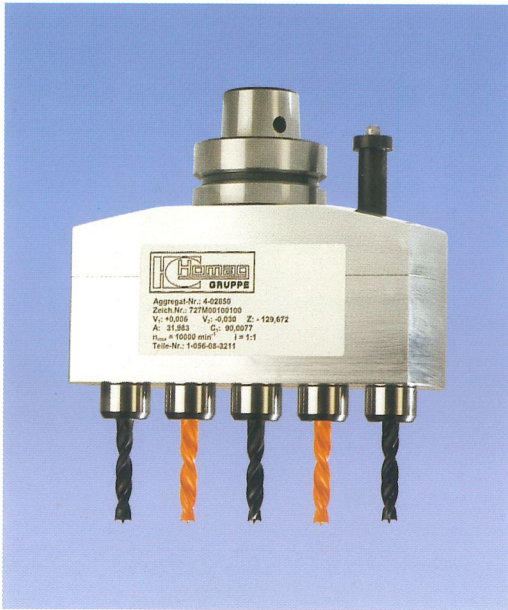

Vertical drilling head
For series holes at any angle with 5 or 7 spindles. Optional spacing possible: 25, 30, 32 or 50 mm.

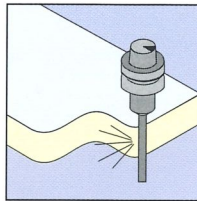

Cleaning air jet
For cleaning trimmed edges of dust and chips.

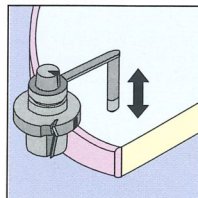
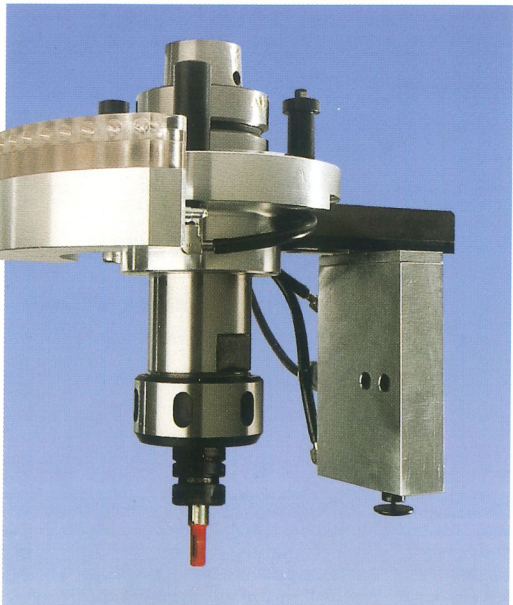
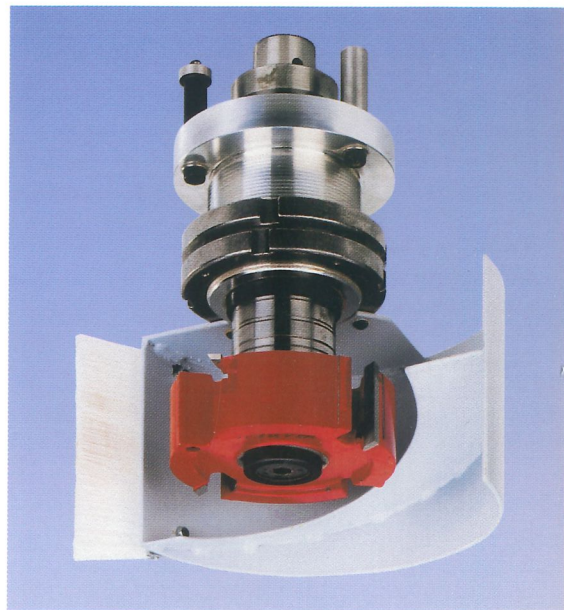

Vertical trimming unit, with electronic tracing
For trimming work on the panel surface, on profiles and edges, with continuous vertical compensation of workpiece and clamping tolerances using the electronic measuring probe. The minimal tracing pressure exerted permits even highly sensitive glossy surfaces to be processed.

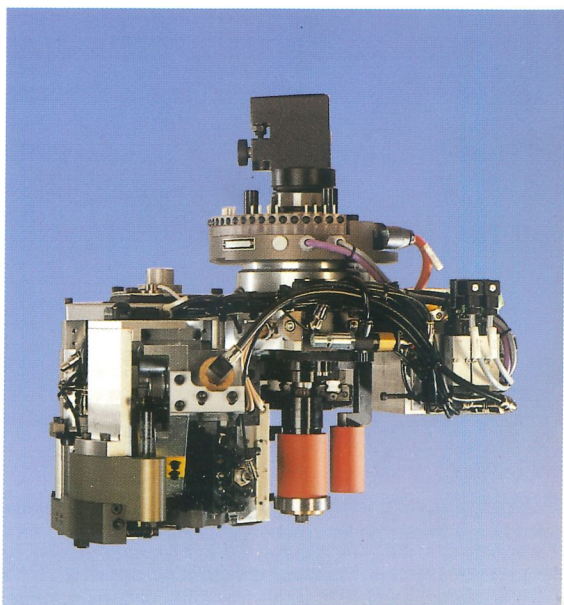

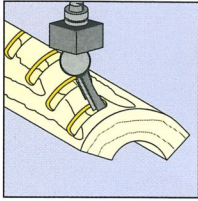

New! Power-driven swivel facility for processing spindle

For trimming work and inclined drilling (5-axis processing).

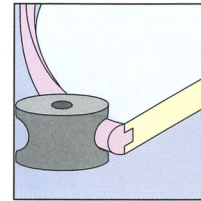
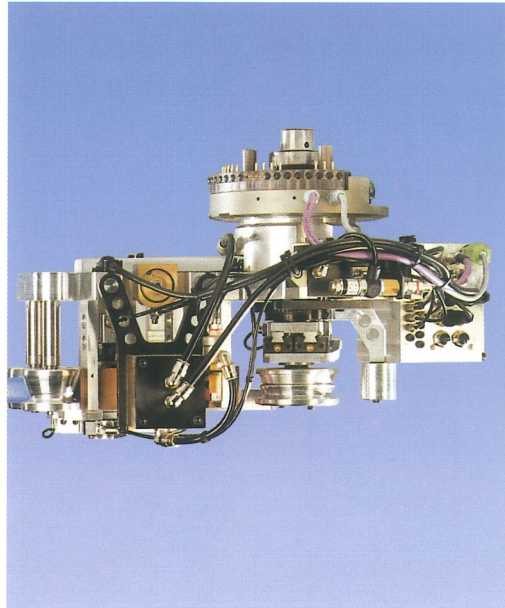

360° T-section material unit

Facility for exchange mounting into the working spindle from a pick-up station, for the automatic application of symmetrical T-section material into a pre-trimmed groove. Unit swivel facility via the C axis.

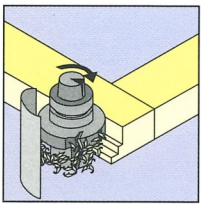

Trimming tool retainer with chip guidance

With deflector plate for optimized chip disposal. Control of the chip deflector plates via the C axis.

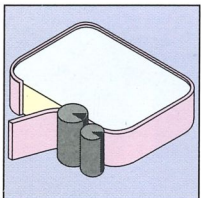

360° gluing unit

360° gluing with butt joint for straight edges with direct glue application. Melting unit and granulate tank, pressing and post-pressing roller. Short-wave radiator to heat thick edging material. Unlimited swivel facility via the C axis.

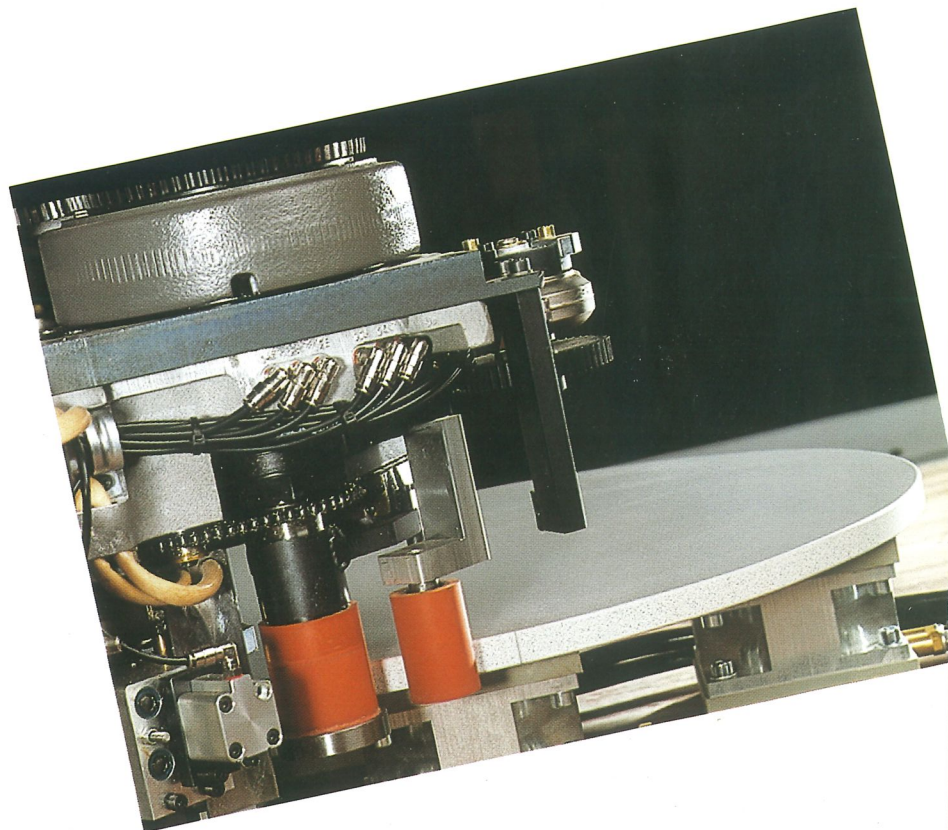

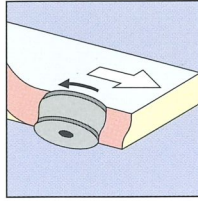
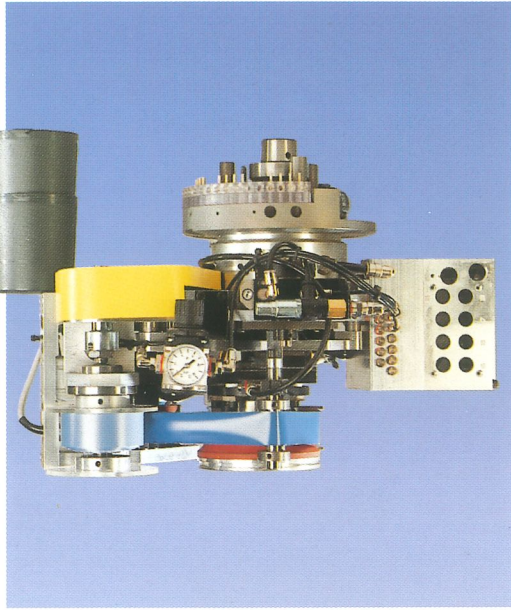

360° transfer finish unit

Facility for exchange mounting into the working spindle from a pick-up station, for application of a finish foil onto suitable substrate material, such as MDF. 360° unit swivel facility via the C axis. Suitable for straight edges or symmetrical, slight drum profiles.

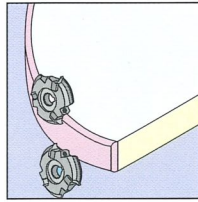
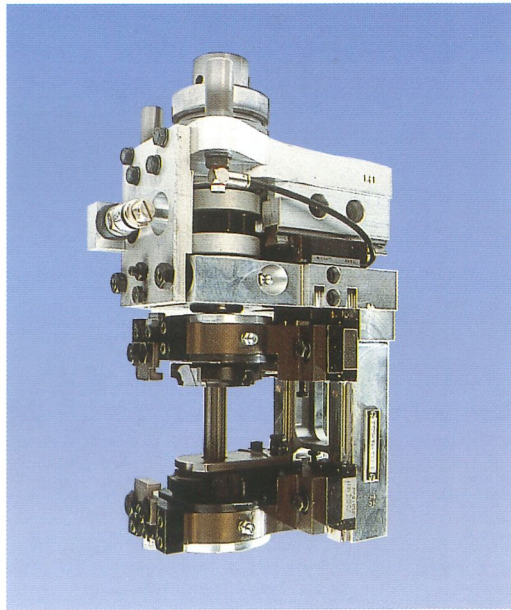
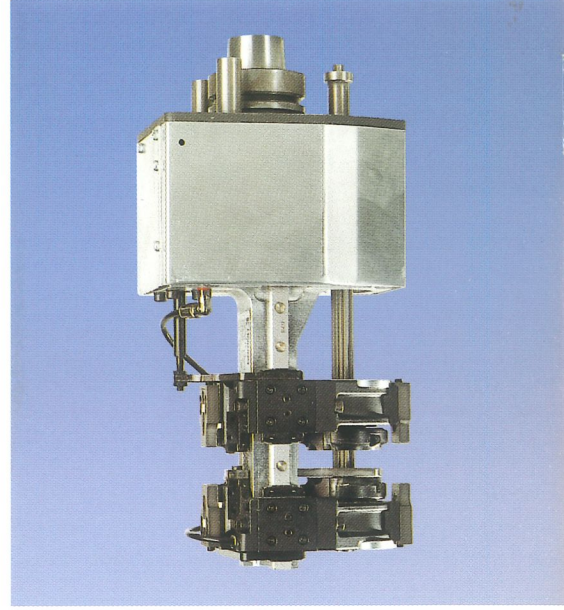

Flush trimming unit

Tracing on three sides to compensate for workpiece and edging tolerances. Contact pressure is applied at right angles to the workpiece contour. Speed up to max. 12.000 rpm.

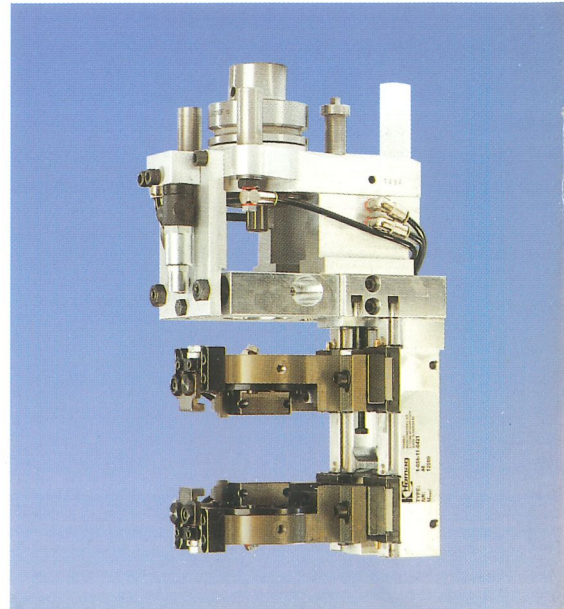
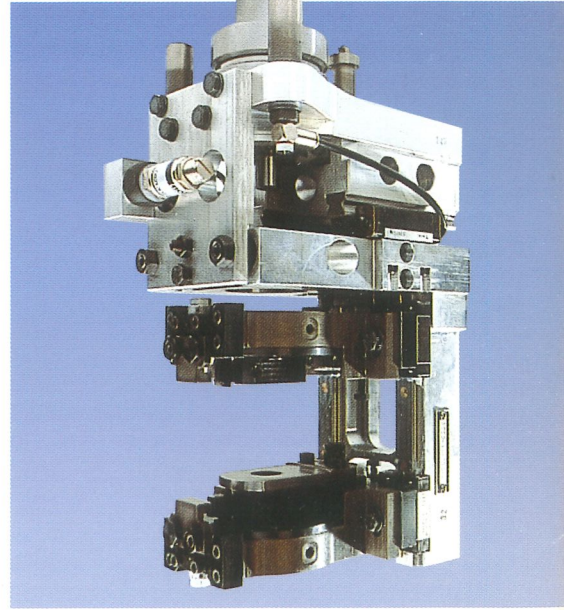

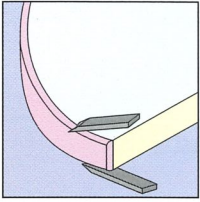
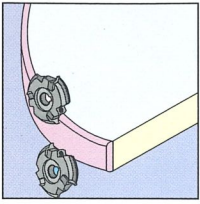
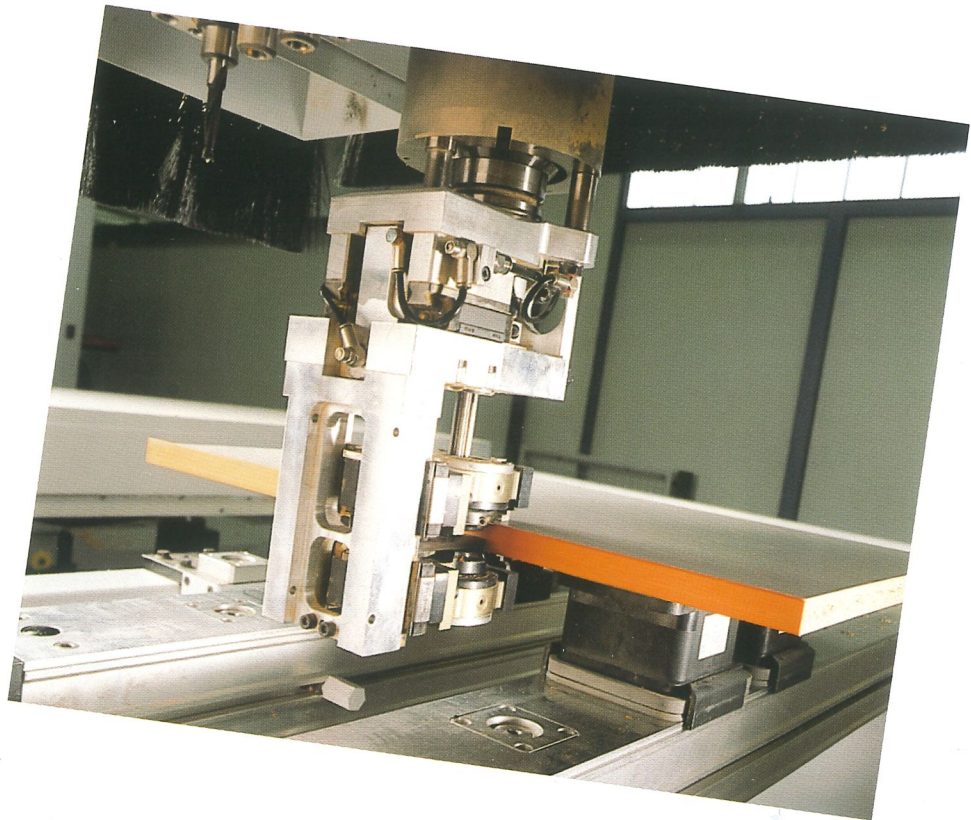

Combined flush trimming and scraping unit

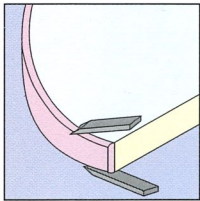

Scraping unit

With tracing on three sides, for compensation of workpiece and edge tolerances. The contact pressure is applied at right angles to the workpiece contour. Available in the form of glue joint or profile scraping device.

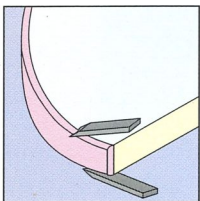

Combined scraping device for profiles / glue joints

Simultaneous top and bottom processing of radii on a pre-trimmed PVC edge. Removal of glue residues in the glue joint area. 360° swivel facility via the C axis.

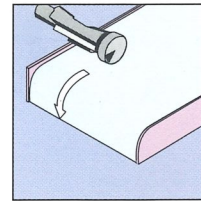
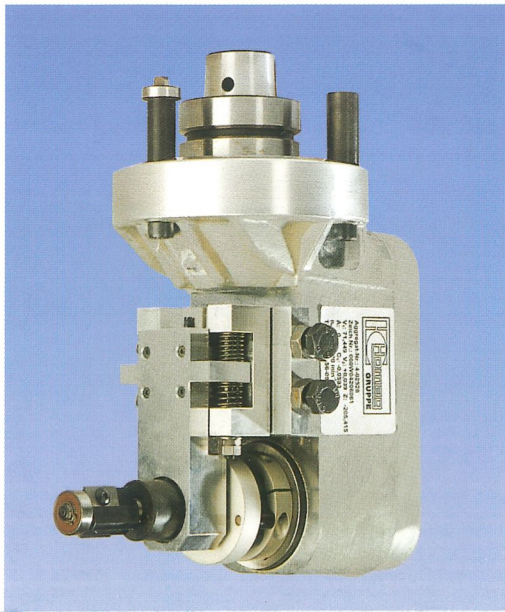

Horizontal trimming unit, with tracing

Trimming spindle for flush trimming of banded transverse edges at a soffforming or postforming profile.

Production



Sales

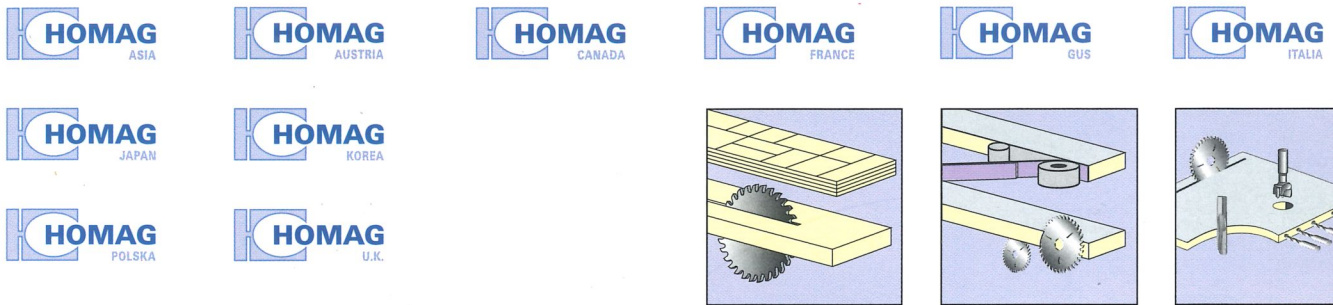

Service

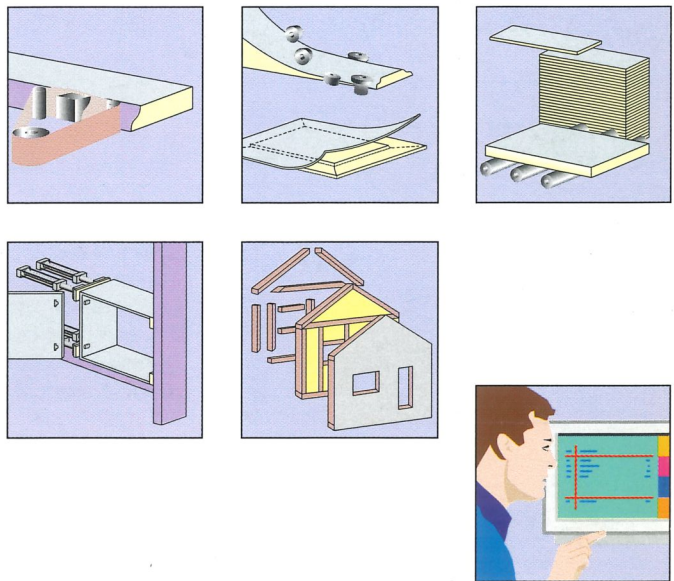

Your contact



HOMAG Holzbearbeitungssysteme AG
 Homagstrasse 3-5
 D-72296 Schopfloch
 Tel. +49 (74 43) 13-0
 Fax +49 (74 43) 13 23 00
 info@homag.de
 http://www.homag.com